

Persci and Shugart Drives Together on the Cromemco 16FDC

Martin Eberhard 22 October 2012

Objective

Cromemco floppy disks and disk images (e.g. .IMD files) are still available various places on the Internet. However, they come in a variety of disk formats: 5.25" disks or 8" disks, single-sided or double-sided versions of both disk sizes, and single-density or double-density for all of these types of disk.

Cromemco originally intended their 4FDC floppy disk controllers to use Persci 277 drives, which are somewhat rare now, and a bit tricky to get working. However, a working Persci drive is a very high-performance floppy drive, with its voice-coil head servo mechanism. The Cromemco 16FDC also supports the Persci 299 drive, which is the 2-sided, double density equivalent of the 277, and is even rarer than the 277. Shugart 8" drives (the SA800 and SA850) are much more common.

The objective of this paper is to allow combinations of Persci and Shugart drives to work together with a Cromemco 16FDC controller. For example, if you own a Persci 277 drive, you might like to keep that as the primary drive on your Cromemco system, but still have the ability to read all of the drive types, so you can read all types of disk images. You would therefore need to have one 2-sided, double-density 5.25" drive, as well as one 2-sided, double-density 8" drive, in addition to your Persci drive (which appears as 2 drives). Your configuration might look like this:

| CDOS/Cromix Drive | Disk Drive Type |
|-------------------|---------------------------------|
| A | Left half of Persci 277 or 299 |
| B | Right half of Persci 277 or 299 |
| C | 2SDD 5.25" drive (e.g. SA450) |
| D | Shugart SA851 2SDD drive |

Drive C is simple - the 5.25" drive is configured as drive C (without a terminating resistor) and is connected to the 16FDC via J2. The 8" drives are a little trickier - this paper describes how to configure 8" drives so that they work together on the Cromemco 16FDC's 50-pin interface.

Background

The Cromemco 16FDC floppy disk controller has two connectors for connecting floppy disk drives. J2 is a 34-pin header for 5.25" disks, and J3 is a 50-pin header that is intended for Persci-type 8" disks.

Persci's 50-pin drive pinout differs from the standard Shugart 8" disk drive pinout. However, it is reasonably simple to support (single-sided) Shugart 800 drives by configuring the SA800 drive correctly, as shown on page 6.

But, the 16FDC does not provide the signal "TG43" (Track Greater than 43) on J3. This signal is required by SA850 drives to reduce write current on the inner tracks, especially when writing a double-density disk. This signal is available as an output pin from the 16FDC's WD1793 Floppy Disk Controller IC, but it is not connected to anything. The 16FDC therefore cannot reliably write double-density disks on SA850 drives without modification.

Also, the SA850 uses a few more signals on its 50-pin interface than does the SA800, mostly related to 2-sided disk detection and operation. These additional signals conflict with Persci signals on the same pins.

Pinout Comparison

Here are is a pinout comparison between the 16FDC, the Persci 277 (single-sided) and 299 (double-sided) drives as configured for the Cromemco 16FDC, and the Shugart SA800 (single-sided) and SA850 (double-sided) drives. The pink cells indicate conflicts.

| Pin | 16FDC | | Persci 277 | | Persci 299 | | Shugart 800 | | Shugart 850 | |
|-----|----------------|-----|-----------------------|-----|-----------------------|-----|------------------|-----|----------------------|-----|
| | Signal | Dir | Signal | Dir | Signal | Dir | Signal | Dir | Signal | Dir |
| Odd | GND | | GND | | GND | | GND | | GND | |
| 2 | Side Select | out | N/C | | Side Select | in | N/C | | Write-Current Switch | in |
| 4 | -DS4 | out | -DS2 right | in | -DS2 right | in | N/C | | N/C | |
| 6 | N/C | | -Ready 1 (1) | out | -Ready 1 (1) | out | N/C | | N/C | |
| 8 | N/C | | -Index 1 (2) | out | -Index 1 (2) | out | N/C | | N/C | |
| 10 | -Seek Complete | in | -Seek Complete | out | -Seek Complete | out | N/C | | -2 Sided (6) | out |
| 12 | -Restore | out | -Restore | in | -Restore | in | -Disk Change (7) | out | -Disk Change (7) | out |
| 14 | -Eject | out | -Eject 0 | in | -Eject 0 | in | N/C | | Side Select | in |
| 16 | N/C | | -Direct Head Load (3) | in | -Direct Head Load (3) | in | -In Use | in | -In Use | in |
| 18 | -DS3 | out | -DS2 left | in | -DS2 left | in | -Head Load | in | -Head Load | in |
| 20 | -Index | in | -Index 0 | out | -Index 0 | out | -Index | out | -Index | out |
| 22 | -Ready | in | -Ready 0 | out | -Ready 0 | out | -Ready | out | -Ready | out |
| 24 | -Motor On | out | -Motor On | in | -Motor On | in | -Sector (8) | out | -Sector (8) | out |
| 26 | -DS1 | out | -DS1 left | in | -DS1 left | in | -DS1 | in | -DS1 | in |
| 28 | -DS2 | out | -DS1 right | in | -DS1 right | in | -DS2 | in | -DS2 | in |
| 30 | N/C | | -Write Prot 1 (4) | out | -Write Prot 1 (4) | out | -DS3 | in | -DS3 | in |
| 32 | N/C | | -Eject 1 (5) | in | -Eject 1 (5) | in | -DS4 | in | -DS4 | in |
| 34 | DIRC | out | DIRC | in | DIRC | in | DIRC | in | DIRC | in |
| 36 | -Step | out | -Step | in | -Step | in | -Step | in | -Step | in |
| 38 | -Write Data | out | -Write Data | in | -Write Data | in | -Write Data | in | -Write Data | in |
| 40 | -Write Gate | out | -Write Gate | in | -Write Gate | in | -Write Gate | in | -Write Gate | in |
| 42 | -Track 00 | in | -Track 00 | out | -Track 00 | out | -Track 00 | out | -Track 00 | out |
| 44 | -Write Prot | in | -Write Prot 0 | out | -Write Prot 0 | out | -Write Prot | out | -Write Prot | out |
| 46 | -Read Data | in | -Read Data | out | -Read Data | out | -Read Data | out | -Read Data | out |
| 48 | N/C | | -Sep Data | out | -Sep Data | out | -FM Sep Data | out | -FM Sep Data | out |
| 50 | N/C | | Sep Clock | out | Sep Clock | out | -FM Sep Clock | out | -FM Sep Clock | out |

- (1) In the standard Cromemco configuration, Persci drives will drive both Ready 0 and Ready 1 to indicate ready
- (2) In the standard Cromemco configuration, Persci drives will drive both Index 0 and Index 1 to indicate Index
- (3) In the standard Cromemco configuration, the drives load their heads when they are selected, and do not use the Head Load signal.
- (4) In the standard Cromemco configuration, Persci drives will drive both Write Prot 0 and Write Prot 1 to indicate Write Protect
- (5) In the standard Cromemco configuration, Persci drives will ignore Eject 1
- (6) This output can be disabled with the "2S" jumper on the SA850
- (7) This output can be disabled with the "DC" jumper on the SA800 and the SA850
- (8) SA 801/SA851 (hard sectored) option. This output is disabled with the "S" jumper on the SA800 and SA850.

Sharing the Interface

Sharing the 16FDC's J3 interface with both a Persci drive and a Shugart SA850 drive requires a minor modification to the 16FDC, an adapter cable between the 16FDC and the SA850, and correct configuration of the SA850. The Persci drive stays as Cromemco originally configured it.

16FDC Modification

Add two jumper wires to the (Rev E) 16FDC to bring the TG43 signal to J3 pin 32, using a spare inverting buffer in U11. (Pin 32 is the only pin that is not connected on the 16FDC, and also not connected on Persci drives, when they are configured for Cromemco 16FDC application.)

- (1) Jumper from IC26 pin 9 to IC11 pin 4.
- (2) Jumper from IC11 pin 5 to J3 pin 32

Adapter Cable

Fabricate a short (3") adapter cable like this:

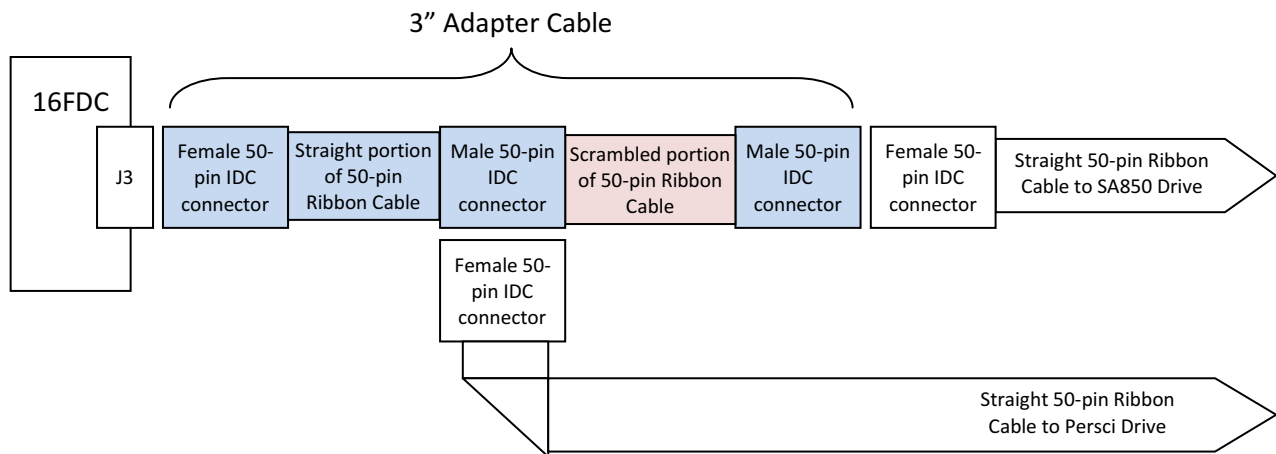

The Adapter Cable can be fabricated by starting with a ribbon cable that is a couple of inches longer than the final adapter will be. Crimp the left two connectors (for the 16FDC and the Persci drive) in place, about an inch and a half apart. Slit the ribbon cable for a couple of inches between the groups of wires in the table below. Carefully route the groups of wires to the right-hand connector (for the SA850), according to the following table, and clamp the connector shut. Trim off the excess ribbon cable.

| 16FDC Side | SA850 Side | Signal |
|------------|------------|--------------------|
| 1,2 | 13,14 | GND & -Side Select |
| 3,4 | 31,32 | GND & -DS4 |
| 5-12 | 5-12 | (Unchanged) |
| 13,14 | No Connect | GND & -Eject |
| 15,16 | 15,16 | (Unchanged) |
| 17,18 | 29,30 | GND & -DS2 |
| 19-28 | 19-28 | (unchanged) |
| 29,30 | No Connect | GND & No Connect |
| 31,32 | 1,2 | GND & -TG43 |
| 33-50 | 33-50 | (unchanged) |

SA850 Configuration

Configure the jumpers on the SA850 as follows:

| Jumpers | Setting | Purpose |
|----------------------|----------------------|--|
| R-Pack at 5E | Removed (1) | No termination (Termination is in the Persci drive.) |
| DS1-DS3 | Open | Not Drive Select from interface pins 26,28,30 |
| DS4 | Jumper | Drive Select from interface pin 32 |
| 1B-4B | Open | No Side Select using drive select |
| RR | Jumper | No radial Ready (jumper disables this option) |
| RI | Jumper | No radial Index (jumper disables this option) |
| R | Jumper | -Ready output to interface pin 22 |
| 2S | Open | No "-2-sided disk detected" output to interface pin 10 |
| 850/851 | 851 Jumpered | Soft-sectored disks |
| I | Jumper | -Index output to interface pin 20 |
| S | Open | No -Sector output to interface pin 24 |
| DC | Open | No -Disk Change output to interface pin 12 |
| HL | Jumper | Stepper power from Head Load & Door Closed (note A,B,X) |
| DS | Open | No stepper power from Drive Select |
| WP/NP | WP Jumpered | Write inhibited when disk Write Protect notch is present |
| D | Open | No In-Use input from the interface pin 16 |
| M | Open | No multimedia option |
| DL | Open | No door latch option |
| A,B,X | All Jumpered | Head load from Drive Select |
| C | Open | No -Head Load input from the interface pin 18 |
| Z | Jumper | In-Use from Drive Select |
| Y | Open | No In-Use from Head Load |
| S1 | Open | No Side Select from Direction Select |
| S2 | Jumper | Normal Side Select from interface pin 14 |
| S3 | Open | No Side Select from Drive Select |
| TS, FS | FS Jumpered | Standard Data Separator Option |
| IWI/IWG | IWI Jumpered | Head current switching from interface pin 2 |
| RS/RM | RS Jumpered | Standard Ready signal |
| HLL | Open | No Head Load Latch |
| IT | Jumper | In-Use terminator (used as pullup) |
| HI | Open | No Head Load or In-Use to the In-Use Circuit |
| F (or FM) | Open | No M2FM encoding |
| AF/NF (or MFM/ M2FM) | AF (or MFM) Jumpered | Active Read Filter for reading FM and MFM |

Notes: (1) If this drive does not have the terminator resistor pack, then install a 150-ohm resistor between pins 1 and 14, and another between pins 5 and 10 at the R-pack location, 5E.

Persci 277 Configuration

For reference, here are the standard jumper and optional component settings for a Persci 277 drive (Persci assembly number 200131-006) in a Cromemco system. The “Nearest IC” column will help you find the jumpers on a Persci 277, though these locations may be incorrect for some versions of the Persci 277.

| Jumpers | Nearest IC | Setting | Component | Nearest IC | Value |
|-------------|------------|-----------|-----------|------------|--------|
| Ull | U11 | 2-13,4-11 | R88 | U10 | 36K |
| 2,4,8,16,32 | U16 | None | R94 | U10 | 36K |
| 2,4,8,16,32 | U27 | None | C40 | U10 | 0.1 uF |
| A,B,C | U17 | A-B | C41 | U10 | 0.1 uF |
| D,E | U17 | None | U16 | | None |
| F,G | U17 | None | | | |
| H,J,Z | U4 | J-Z | | | |
| K,L | U8 | K-L | | | |
| M,N,P | U3 | N-P | | | |
| R,S,T | U3 | S-T | | | |
| U,V | U9 | U-V | | | |
| W,X,Y | U10 | W-X | | | |
| AA,AB,AC | U15 | AB-AC | | | |
| AD,AE,AF | U15 | AD-AE | | | |
| AH,AJ,AK | U10 | AH-AJ | | | |
| AL,AM,AN | U1 | AL-AM | | | |
| AP,AR | U8 | AP-AR | | | |
| AS,AT,AY | U3 | AS-AT | | | |
| AU,AV,AW | U11 | AV-AW | | | |
| BA,BB,BC | U3 | BA-BB | | | |
| BD,BE | U7 | BD-BE | | | |
| BF,BH,BJ | U15 | None | | | |
| BK,BL,BM | U3 | BK-BM | | | |

Shugart SA800 Configuration

For reference, here are the Shugart SA800 Jumper settings for use on a Cromemco 16FDC, potentially sharing the interface with a Cromemco-configured Persci drive. No wiring changes are required: a Shugart SA800 drive that is configured this way will work with the 4FDC or 16FDC controller, and can share the interface with a Persci 277 or 299 drive. (You need a 16FDC to use a Persci 299 drive.)

| Jumpers | Jumper Position | Comment |
|-----------------|------------------------|--|
| T1, T3-T6 | Jumper for termination | Not Jumpered if the Persci drive is terminated |
| DS1-DS4 | DS1-DS4 | Drive select from interface pins 26,28,30,32 |
| RR | Jumper | Radial Ready when removed |
| RI | Jumper | Radial Index & Sector when removed |
| R | Jumper | Ready Output to interface pin 22 |
| 800/801 | 800 Jumpered | Soft-sectored disks |
| I | Jumper | Index output to interface pin 20 |
| S | Open | No Sector output to interface pin 24 |
| DC | Open | No Disk Change output to interface pin 12 |
| HL/DS | HL Jumpered | Stepper power from Head Load & Door Closed (note A,B,X) |
| WP/NP | WP Jumpered | Write inhibited when disk Write Protect notch is present |
| D | Open | No In-Use Input from the interface pin 16 |
| D1, D2, D4, DDS | Open | No user-installed drive decode |
| A,B,X | All Jumpered | Head load from Drive Select |
| C | Open | No Head Load input from the interface pin 18 |
| Y/Z | Z Jumpered | In-Use from Drive Select (not from head load) |
| DFO | Open | No Non Force Output |
| TS | Open | No true FM data separation |